

Original BMW Accessories. Installation Instructions.



M Performance Footrest Retrofit

BMW 6 Series Gran Coupé (F 06)

BMW 5 Series Saloon (F 10)

BMW 5 Series Touring (F 11)

BMW 6 Series Convertible (F 12)

BMW 6 Series Coupé (F 13)

BMW 1 Series 5-door (F 20)

BMW 1 Series 3-door (F 21)

BMW 3 Series Saloon (F 30)

BMW 3 Series Touring (F 31)

Retrofit kit number

51 47 2 280 942 Stainless steel footrest F 10, F 11, F 12, F 13, F 06

51 47 2 232 279 Stainless steel footrest F 20, F 21, F 30, F 31

Installation time

The installation time is **approx. 0.25 hours**. This may vary depending on the condition of the car and the equipment in it.

Important information

These installation instructions are primarily designed for use within the BMW dealership organisation and by authorised BMW service companies.

In any event, the target group for these installation instructions is specialist personnel trained on BMW cars with the appropriate specialist knowledge.

All work must be completed using the latest BMW repair manuals, wiring diagrams, servicing manuals and work instructions, in a rational order, using the prescribed tools (special tools) and observing current health and safety regulations.

If you experience installation or function problems, restrict troubleshooting to approx. 0.5 hours for mechanical work and 1.0 hour for electrical work.

To avoid unnecessary extra work and/or costs, send an inquiry straight away to the technical parts support team via the Aftersales Assistance Portal (ASAP).

Quote the following information:

- Chassis number,
- retrofit kit part number,
- a detailed description of the problem,
- any work already carried out.

Do not archive the hard copy of these installation instructions since daily updates are provided via ASAP!

Pictograms



Denotes instructions that draw your attention to dangers.



Denotes instructions that draw your attention to special features.

◀ Denotes the end of the instruction or other text.

Installation information

All illustrations show LHD cars; no M Performance footrest is available for RHD cars.

Bonding surfaces must be cleaned with cleaning agent and must be completely clean, dry and free from grease or dust. The ambient temperature for bonding work must be no lower than 15 °C and no higher than 35 °C.

Before removing the adhesive film, the installation of the M Performance footrest should first be tried out in order to avoid any mistakes when installing.

Ordering instructions

The M Performance footrest is only available for LHD cars.

Special tools required

none

Table of contents

Section	Page
1 M Performance footrest parts list F 10, F 11, F 12, F 13, F 06.....	4
2 M Performance footrest parts list F 20, F 21, F 30, F 31.....	5
3 Preparatory work	6
4 Installing the M Performance footrest	7

1. M Performance footrest parts list F 10, F 11, F 12, F 13, F 06

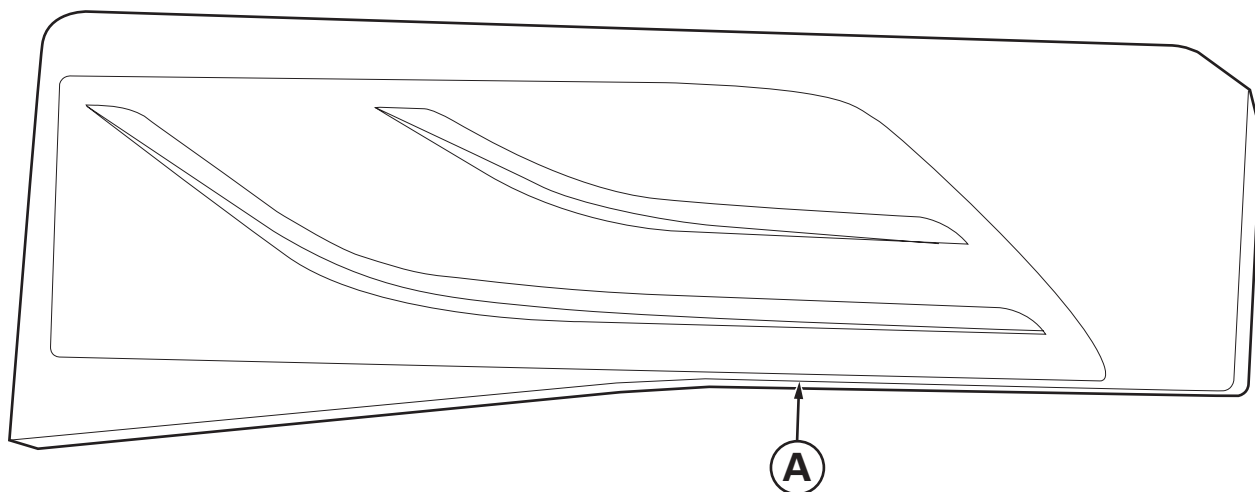

F30 0086 V

Legend

A M Performance footrest

2. M Performance footrest parts list F 20, F 21, F 30, F 31

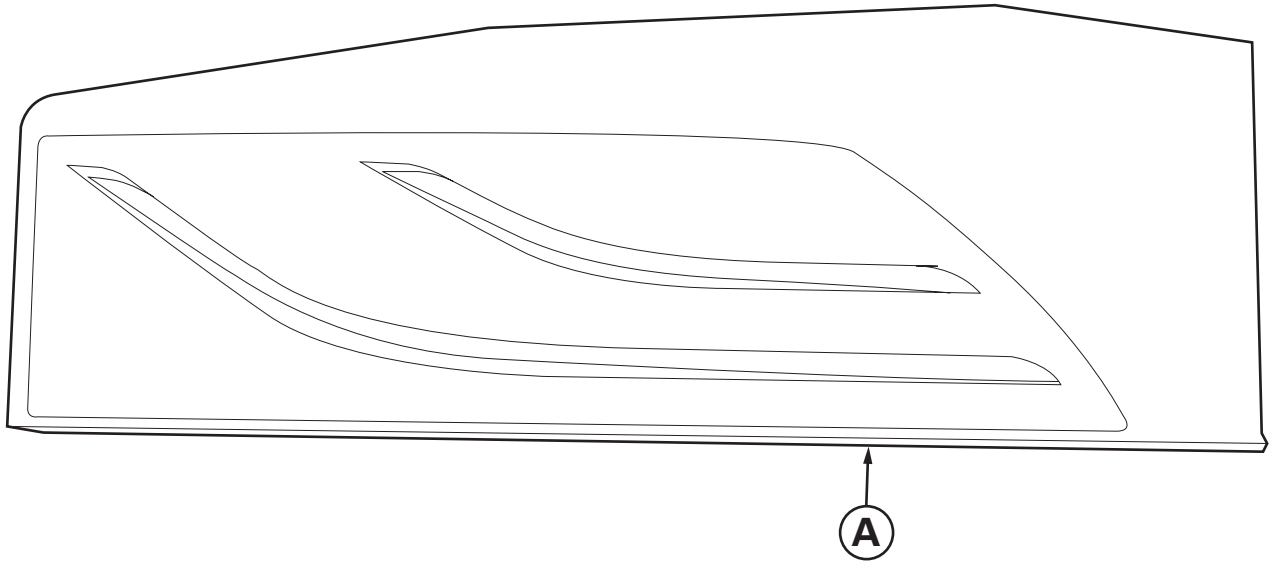

F30 0085 V

Legend

A M Performance footrest

3. Preparatory work

The following components must be removed first of all

ISTA No.

none

4. Installing the M Performance footrest

▶ Installation is shown on the F 30. Proceed accordingly with all other models.

Before removing the adhesive film, the installation of the M Performance footrest should first be tried out in order to avoid any mistakes when installing. ◀

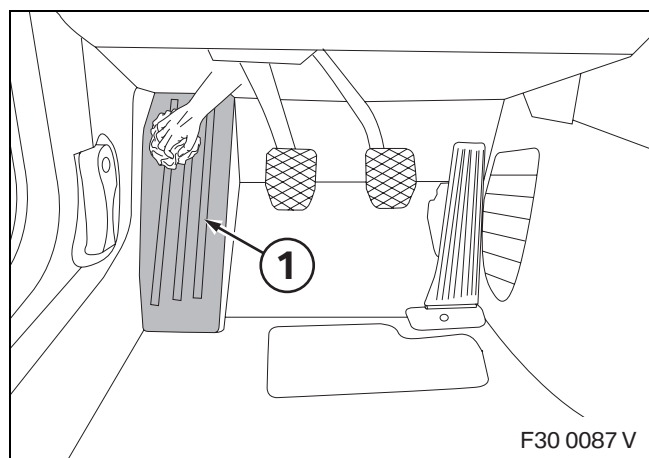

▶ The areas being bonded must be completely dry, clean and free from wax or grease. ◀

Clean the footrest (1) in the driver footwell.

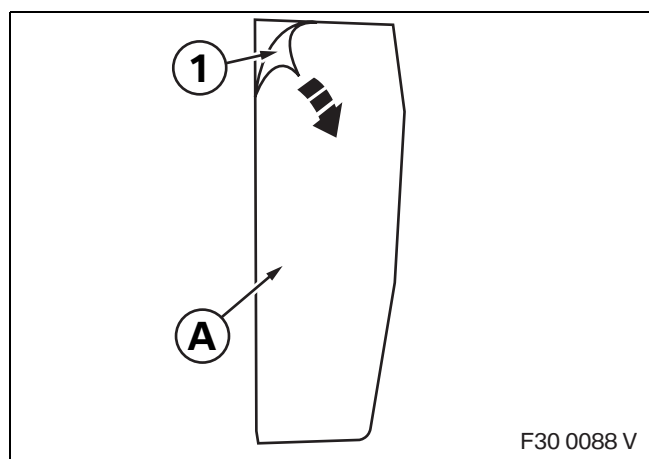

Remove the backing film (1) on the reverse of M Performance footrest **A**.

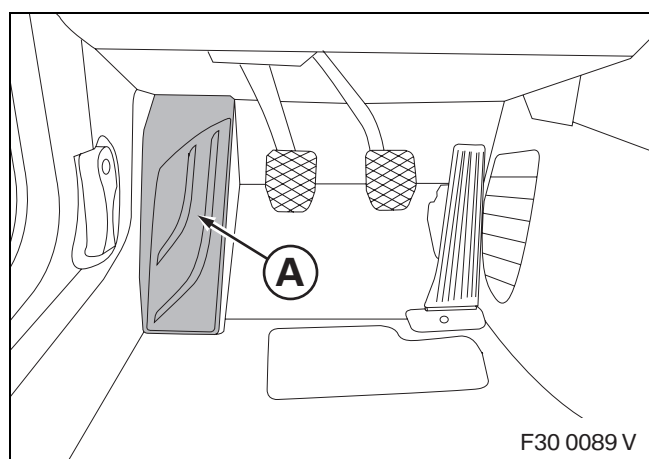

Align M Performance footrest **A** as shown and press it on.

▶ The adhesive tape develops its full adhesive strength after approx. 24 hours. ◀